

Please tape down

Please tape down

3rd Fold

Affix
Stamp



NewTeam Ltd.

Customer Service Dept.
Brunel Road
Earlstrees Industrial Estate
Corby
Northants
NN17 4JW

1st Fold

2nd Fold



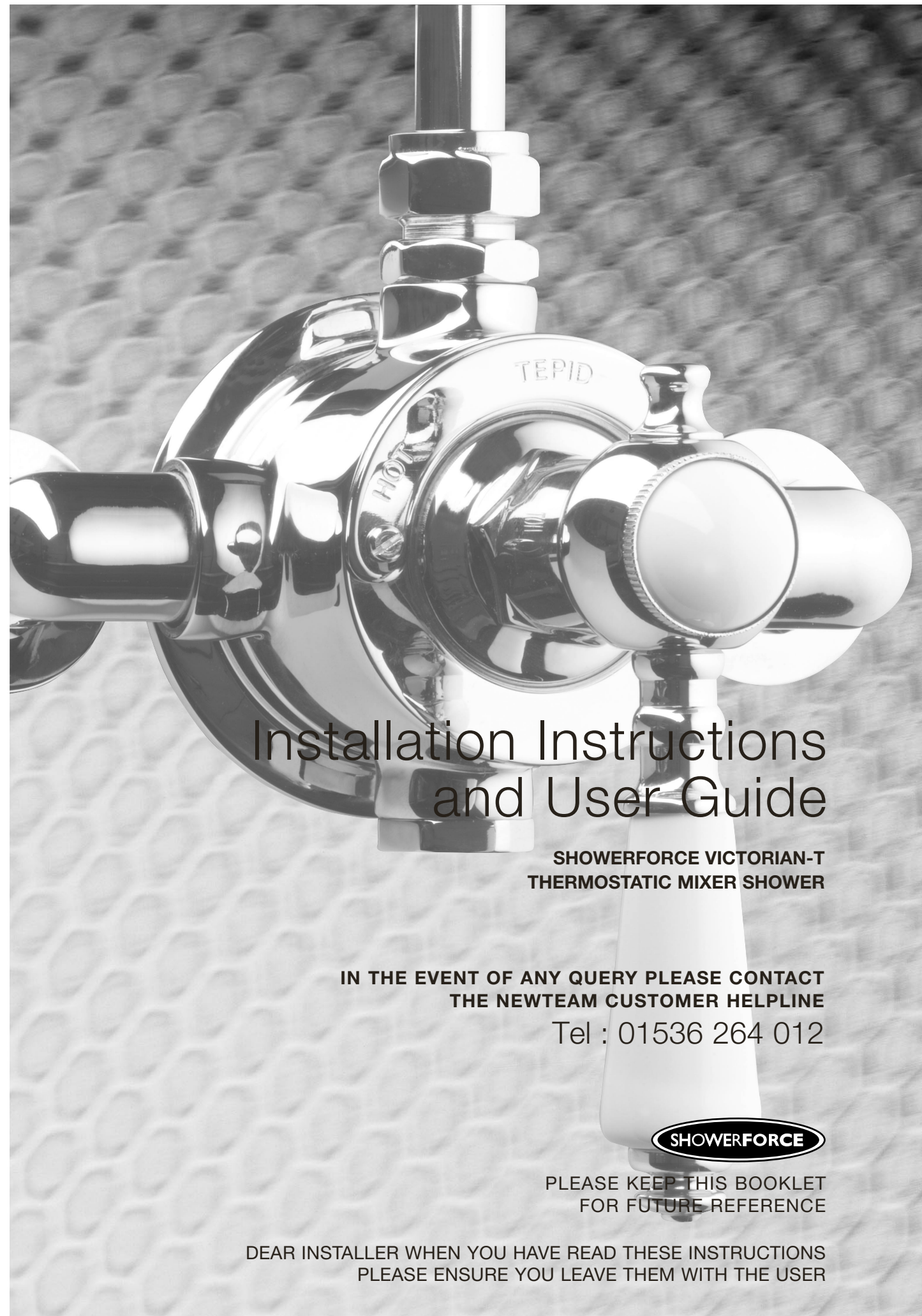

Installation Instructions and User Guide

**SHOWERFORCE VICTORIAN-T
THERMOSTATIC MIXER SHOWER**

**IN THE EVENT OF ANY QUERY PLEASE CONTACT
THE NEWTEAM CUSTOMER HELPLINE**

Tel : 01536 264 012

SHOWERFORCE

**PLEASE KEEP THIS BOOKLET
FOR FUTURE REFERENCE**

**DEAR INSTALLER WHEN YOU HAVE READ THESE INSTRUCTIONS
PLEASE ENSURE YOU LEAVE THEM WITH THE USER**

Product Features

ShowerForce Victorian-T





Contents

Installation and Operating Instructions
for ShowerForce Thermostatic Mixer Shower

• Victorian-T

Please read this booklet carefully and ensure a competent person undertakes the installation.

Note: Following the headings in sequence will guide you through the installation and operation of your ShowerForce Victorian-T Mixer Shower

	Pages
INTRODUCTION	3 - 4
• Site Requirements	
• Gravity Fed	
• General	
INSTALLATION	5 - 8
SERVICE/MAINTENANCE	9
CLEANING & LUBRICATION	10
GUARANTEE	11

Refer to back cover for Guarantee, Customer Service and Replacement Parts Policy.
In the event of any query regarding installation please contact the NewTeam Customer Service Department

Tel: 01536 264 012 • Fax: 01536 409 201

E-mail: service@newteam.co.uk • E-mail: spares@newteam.co.uk

In line with our policy of continual product development the specifications may be varied and product design altered. We reserve the right to depart from the details given in this manual without prior notice.

Introduction

Victorian-T Shower Valve

Installation and operating instructions for the Victorian-T Thermostatic Mixer Shower.

The valve is supplied with the hot inlet on the left and the cold inlet on the right when viewed from the front. The hot supply must be connected to the inlet port marked 'H'.

Please read these instructions carefully, and ensure the shower valve is installed to The Water Supply (Water Fittings) Regulations. If in doubt, contact a registered plumber or the Secretary of Institute of Plumbing, address as follows:

Institute of Plumbing
64 Station Lane
Hornchurch
Essex
RM12 6NB
Tel: 01708 472 791

Site Requirements

To ensure the correct operation of your shower mixing valve it is important to fully understand your site installation. This thermostatic mixing valve will suit the following

- High Pressure
- Low Pressure
- Mains Pressure
- Pumped Pressure
- Unequal Pressure
- Gravity Pressure

The shower mixing valve may require slight adjustment depending on your site installation the following may apply.

Gravity Fed

Fig 1 shows a typical layout. The distance between the bottom of the cold water tank and the shower head must be a minimum of 1 meter (0.1 bar).

Make the connection into the hot water supply pipe from the cylinder ensuring that it is the first draw off on the vertical pipe below the expansion pipe tee. If this is not possible a direct connection must be made from the hot water cylinder with an Essex flange.

The cold water supply should be taken directly from the cold water storage tank positioned 60mm below the cold connection which feeds the hot water cylinder.

The above installation is recommended for most showers, if however your cold supply is mains pressure then the following will be required.

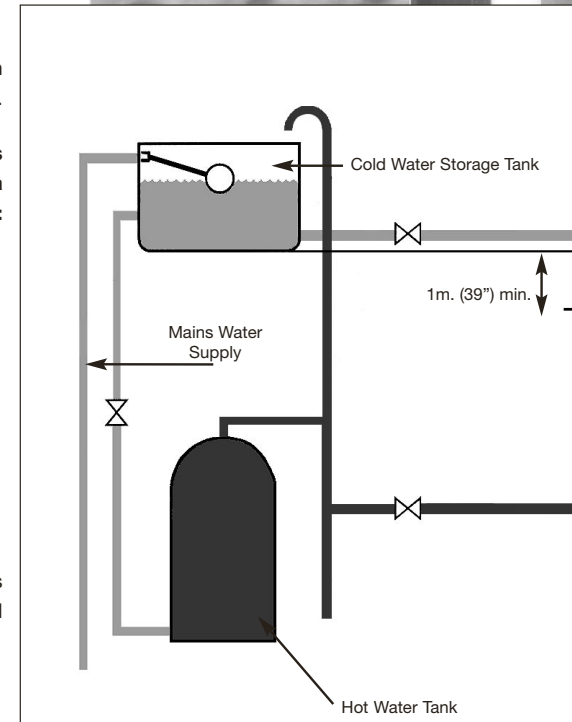
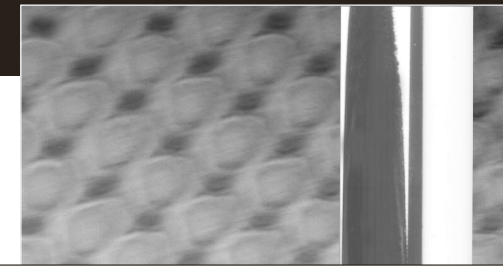

Fig 1 - Typical Installation Diagram



Introduction

Installation (Contd.)

MAINS COLD SUPPLY

A) *Hot supply between 1 to 4 metres (0.1-0.4 bar)
Mains cold supply up to 10 bar.
*Fit 7 litre (green) limiter into cold inlet elbow only.

B) *Hot supply above 5 metre (0.5 bar)
Mains cold supply up to 10 bar.
*Fit 5 litre (yellow) limiter into hot inlet elbow.
*Fit 7 litre (green) limiter into cold inlet elbow.

UNVENTED SYSTEM

Fit 5 litre (yellow) limiter into hot inlet elbow.
Fit 7 litre (green) limiter into cold inlet elbow.

This will give a shower outlet of about 10litres/min. (2.2 gallons per min).
(Cold supply to shower from same source as hot).

INSTANTANEOUS GAS WATER HEATER & COMBINATION BOILER (UNVENTED)

The hot supply from the heater is to be connected to the hot inlet elbow and cold inlet elbow connected to the cold supply. Fit 7 litre flow limiter (as supplied) into the cold inlet elbow.

INSTANTANEOUS (NON STORAGE)

7-9kw Electric Water Heaters (Unvented)

This will require a 5 litre (yellow) flow limiter as supplied into Cold outlet only.

IMPORTANT: It is a requirement of Instantaneous Electric Water Heaters that a stable flow of water passes through the heater.

This requirement can be satisfied by using a Flow Stabilizer and should be adjusted to give a temperature of between 50 & 55°C from the heater.

Flow Stabilizers should be fitted prior to the heater.

PUMPED SHOWERS

Your thermostatic shower is also ideal for power shower installation and can be matched to the ShowerForce range of shower pumps.

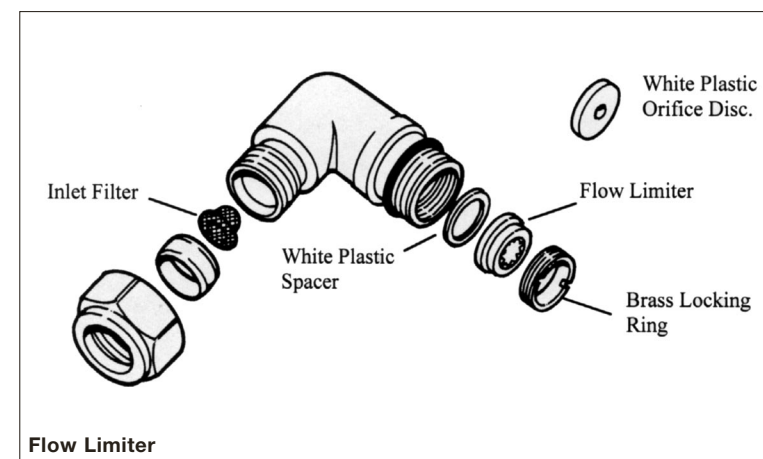
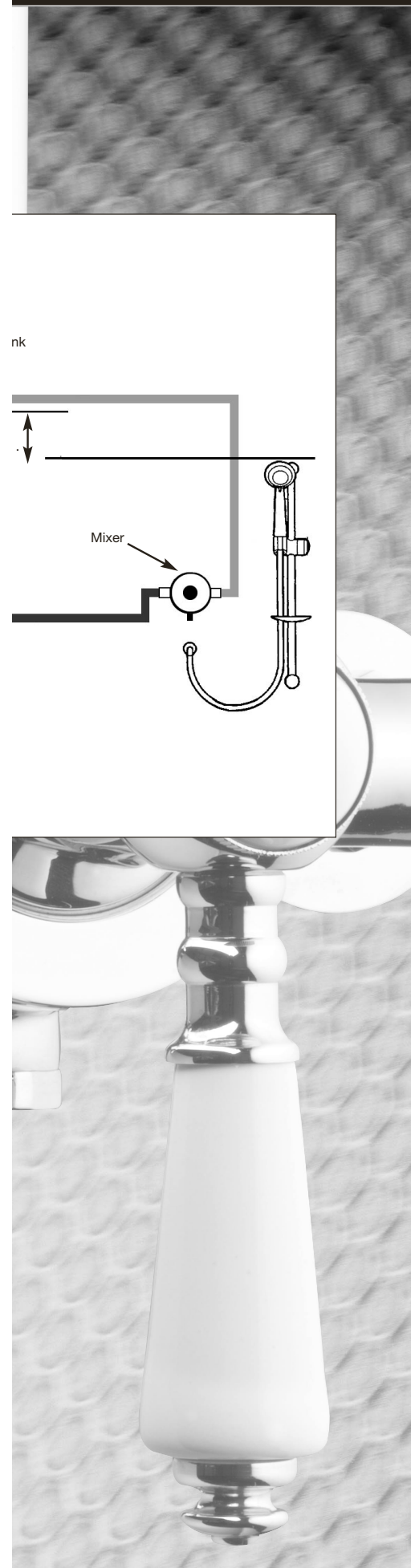

Installation

General

- 1) Before commencing it is advisable to install isolating valves on both hot and cold supplies for flushing out and servicing purpose.
- 2) It is important that both supply pipes are flushed before connecting mixing valves to ensure no pipe/plumbing debris enters the mixing valve.
- 3) A simple way of flushing out the pipes is to fit the outlet adaptor to the pipe and secure with the compression nut and olive, fit the hose to the adaptor and flush out pipes to the waste.
- 4) We recommend fitting the strainers to ensure no debris enters the mixing valve.
- 5) In hard water areas the mixing valve may require more frequent cleaning and servicing.

Pipe Position - Fig 2

Before mounting the valve to the wall, the position for the pipe work should be decided. Three inlet positions - top, bottom and rear are possible simply by rotating the elbows in the valve body (only on exposed versions). With the elbow screwed fully against the valve body it can be unscrewed a maximum of 1.5 turns to allow for lateral tolerance.

Surface Mounting

- 1) Use the surface mounting backplate as a template for the fixing holes.
- 2) Drill and plug the wall to suit, screws are provided. If fixing to a cavity wall use suitable fixings.
- 3) Fit the grubscrew loosely to the backplate and secure the backplate to the wall.
- 4) Locate the valve body to the wall and lock with the grubscrew. Fit the outlet adaptor to the valve - exchange with the blanking plug for top outlet.
- 5) Connect the inlet pipes to the valve with compression fittings, please ensure the hot supply is connected to the inlet port 'H'.

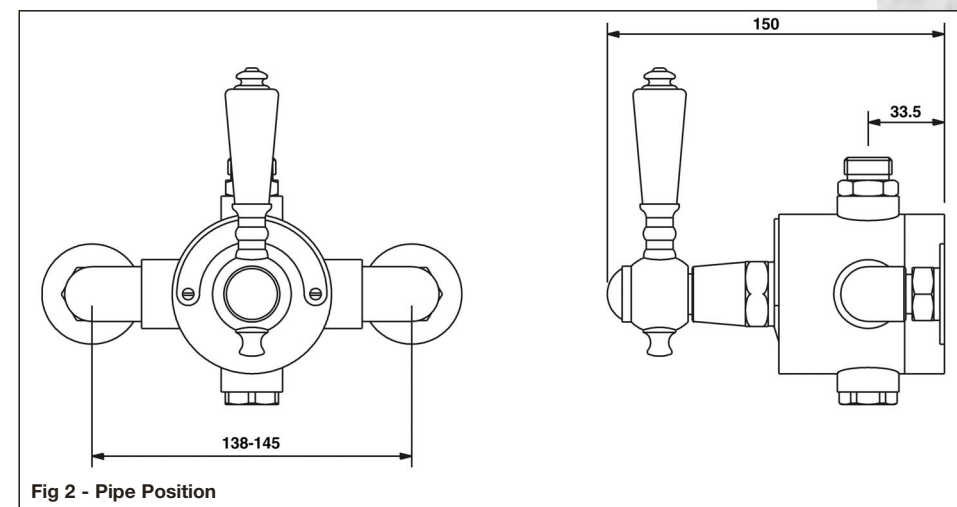

Installation

Temperature Setting

The maximum mixed water temperature should be limited to ensure no undesirable temperature is obtained. If necessary adjust as follows:

- 1) Turn the lever anti-clockwise to the maximum temperature position.
- 2) Remove the lever cap and remove the screw.
- 3) Using a thin flat screwdriver through the center of the spindle, turn the adjusting screw to alter the temperature.

Turn the adjusting screw clockwise for cooler temperature.

Turn the adjusting screw anti-clockwise for warmer temperature.

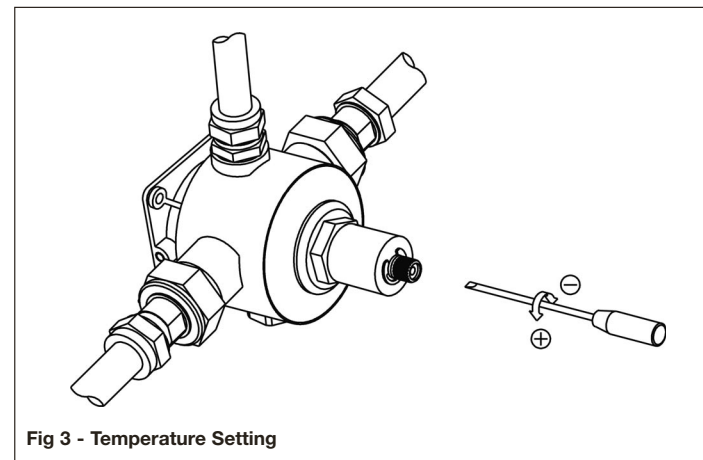

Fitting the Riser Rail

Ensure the valve has been securely fixed to the wall and is in the correct place

For this shower kit you need to assemble the riser, this is done by inserting the risers into the push fit adaptor. (As below).

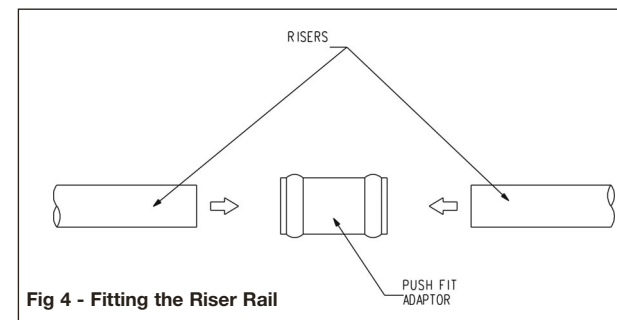

Once that has been done place the riser into the compression adaptor on the top of the shower valve. Now place the exposed shower arm onto the riser (This might be a tight fit) you will now have the location for the three holes. Mark the hole locations and drill and plug, you are then able to secure the exposed shower arm to the wall.

Once everything is secure, screw the shower head onto the arm and the set up is complete.

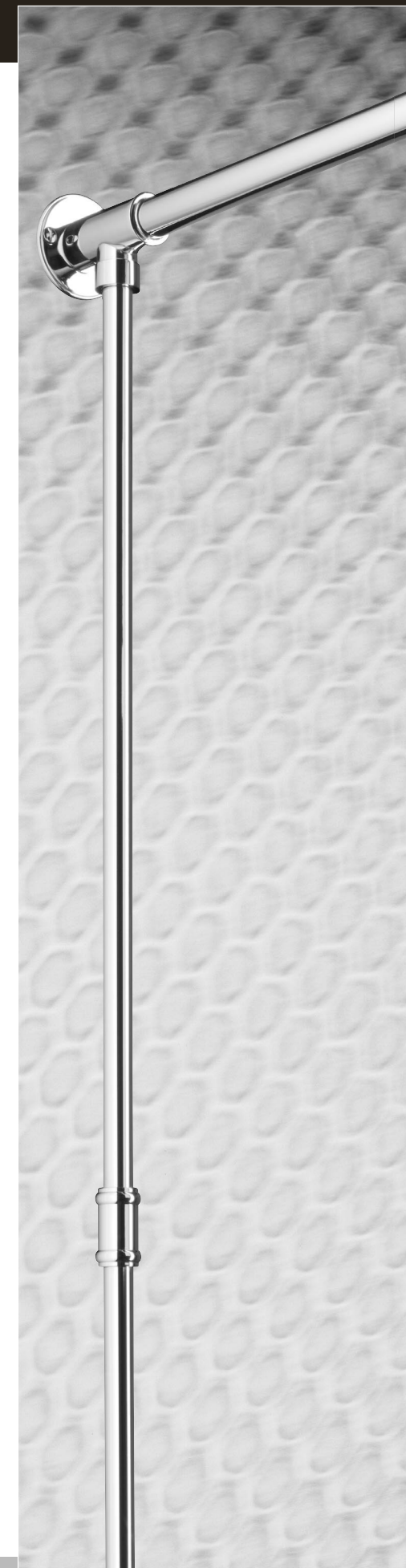
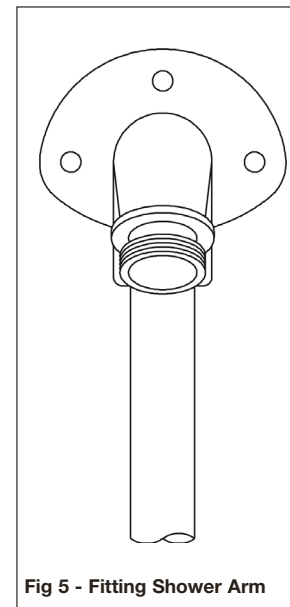

Fitting your Shower

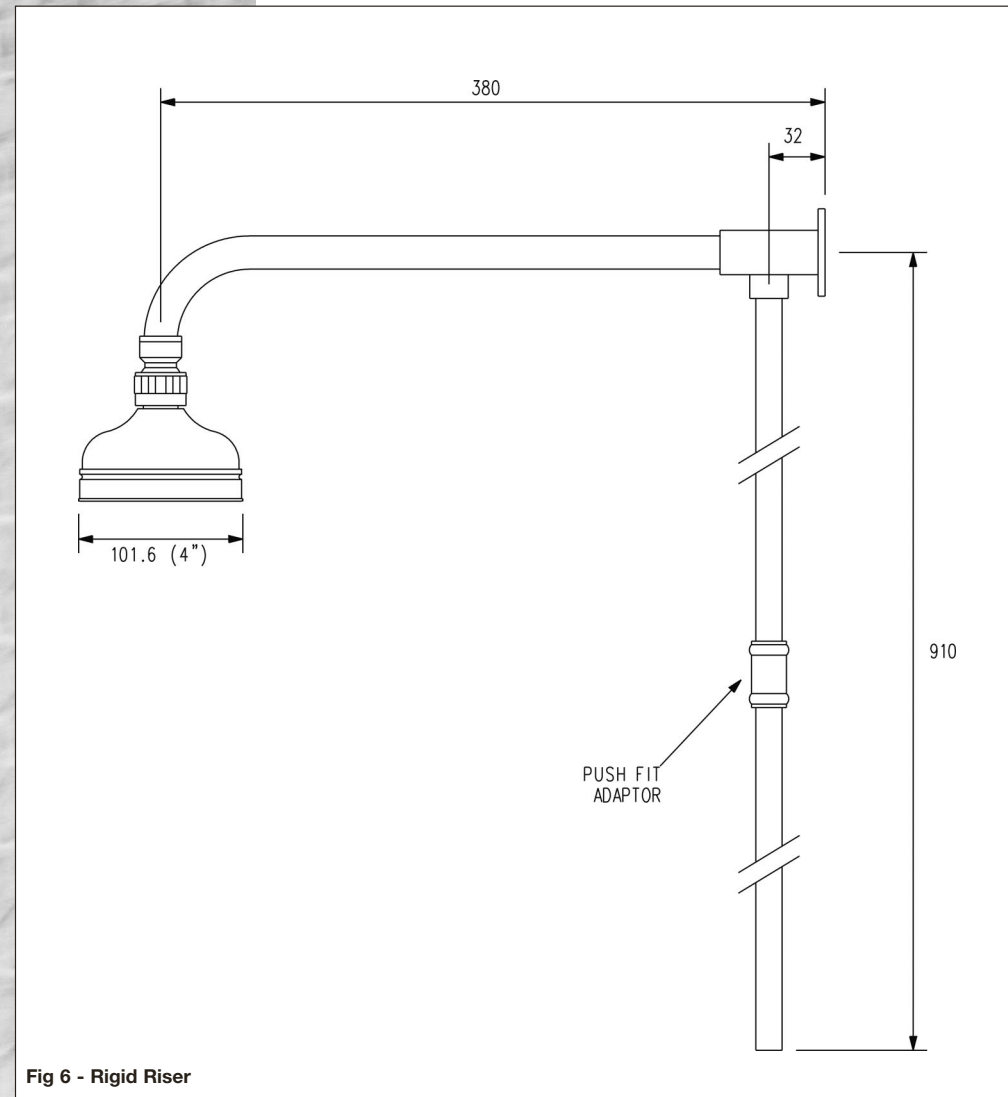

Fig 6 - Rigid Riser

Service/Maintenance

If your Thermostatic Mixing Valve fails to operate it could be the result of incorrect installation. Please refer to installation and sit requirements.

If the valve has operated correctly for a time, but no longer performs acceptably, it may require servicing/cleaning. Proceed as follows;

- 1) Isolate hot and cold supplies.
- 2) Remove the headwork assembly and spline adaptor if applicable
- 3) Unscrew the cartridge (standard right hand thread).
- 4) Remove the thermostat, distributor assembly and spring.
- 5) Remove all visible 'o' rings and washers from the body.

NOTE: Do not adjust the bottom cap setting.

32mm spanner required (standard thread).

Ensure that you DO NOT damage the valve, pipe work or backplate when undoing the headwork.

Ensure that you don't damage the faces of the piston.

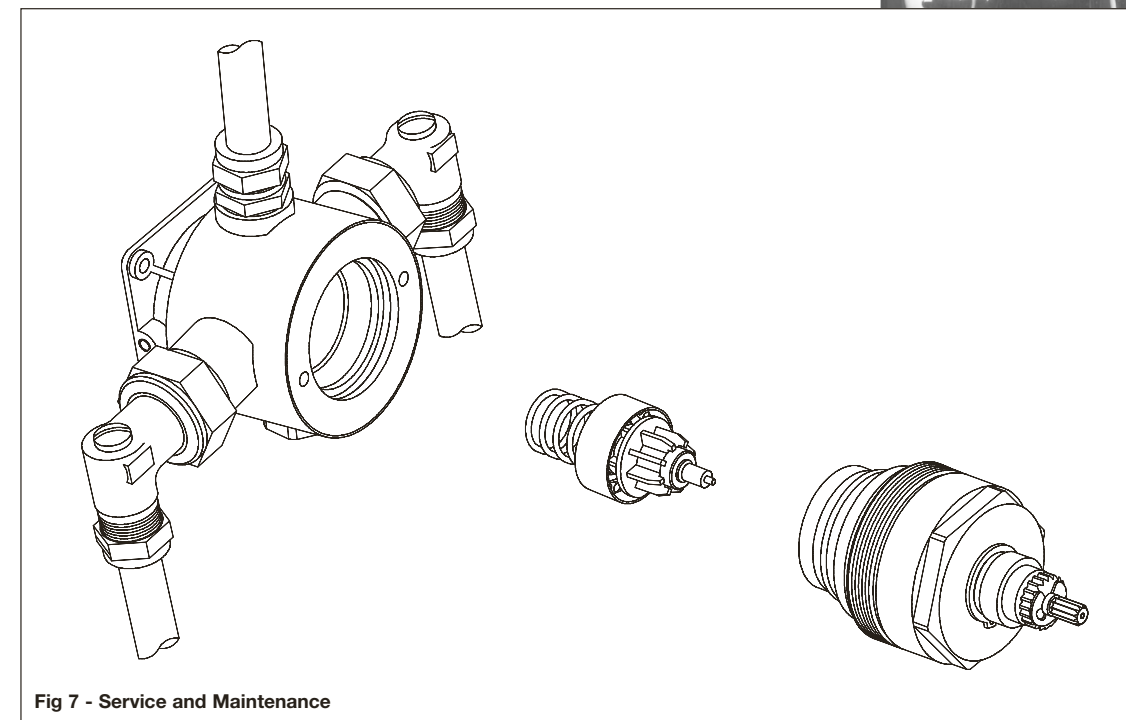

Fig 7 - Service and Maintenance



Cleaning and Lubrication

General

- 1) Soak all metal parts in descalent, wash off in clean water.
- 2) Examine all seals and replace if necessary.
- 3) Use silicon based grease on all seals (light smear only). A maintenance kit is available, which contains all seals and grease from your local stockist or manufacturer.

Re-Assembly

- 1) Replace the spring in the bottom of the valve followed by the piston and thermostat.
- 2) Screw the cartridge back into the shower valve and fully tighten.
- 3) Replace the sleeve and push the knob back into place, replace the screw and knob cap

NOTE: Do not adjust the bottom cap unless you are installing a new cartridge. If this is the case, screw the bottom cap fully clockwise until it stops, then unscrew anti-clockwise 3/4 turn only.

General Fault Diagnosis

If your Thermostatic Mixing Valve fails to operate either immediately upon installation or after a period of time, the following points should be checked;

- 1) Isolate supplies and ensure that both hot and cold supplies are reaching the valve body. You may need to dis-connect supply pipes to ensure this.
- 2) Ensure that there is no debris between the faces of the piston and it's mating faces, the bottom of the valve body and the cartridge.
- 3) Check that the valve has been installed correctly in accordance of its particular feed system (i.e use of flow limiters where necessary).
- 4) Check that the hot water temperature source is sufficient; preferred minimum of 60°C.

Spare Parts

Part No.	Description
SK 1500 - 1	Seals Kit
SK 1500 - 7 GP	Cartridge Kit
SK 1500 - 3	Thermostat and Piston Assembly
SK 1500 - 12	Flow Limiter Kit

Installers Notes



Installers Notes



Guarantee/Service Policy

Guarantee

Thank you for purchasing a ShowerForce product, which has been designed, manufactured and tested, in the U.K., to the highest standards, by NewTeam Ltd.

Guarantee. 1 Year - Parts and Labour

This is provided that:

1. The guarantee registration card is completed and returned within ten days complete with a copy of proof of purchase.
2. The product is installed and operated in accordance with our instructions and has not been misused or damaged.

This in no way affects your statutory rights as a consumer.

The information on the Guarantee card helps ShowerForce to process any claims and contact you about your product and its maintenance if required. The registration of your personal details is purely for Showerforce use, and the other information helps us to make products for the future.

ShowForce Shower products are designed, manufactured and tested to the highest standards.

Should a complaint arise, products are guaranteed against faulty workmanship and materials for a period of 12 months from the date of purchase, when in domestic use (second year guarantee is parts only). For your guarantee to be valid, your shower pump must be installed by a competent person, in accordance with the instruction manual.

ShowForce will repair or replace (at our option), free of charge, any faulty components during the guarantee period, provided it has been maintained and operated in accordance with our instructions, and has not been misused or damaged.

Modification or repair of this product by person(s) not authorised by Showerforce will invalidate this guarantee.

This guarantee applies to products purchased within the United Kingdom or Republic of Ireland, but does not apply to products used commercially.

This guarantee does not affect your statutory rights.

Service Policy - Replacement Parts Policy

IMPORTANT:

In the event of product or component malfunction, DO NOT tamper with or remove the product from site. Telephone ShowerForce Customer Service Department on 01536 264 012 and be prepared with the date of purchase, model number and a description of the complaint.

Our service staff are fully qualified to advise on correct installation procedures and will be able to diagnose whether the fault will require a replacement part or a visit from a ShowerForce engineer.

If required, a service call will be booked, and either yourself or an appointed representative (who should be a person of 18 years or over) must be present during the visit.

All site visits to product within the guarantee period will be carried out free of any parts or labour charges provided the conditions of the guarantee have been adhered to. (Second year guarantee is parts only)

All site visits to product out of guarantee will be subject to charges for parts and labour which is payable by you or your appointed representative at the time of the visit. Charges will also be levied on cancelled appointments, unless advised to ShowerForce at least 24 hours in advance of the agreed date and time.

We reserve the right not to undertake work where payment cannot be made to our engineer at the time of the visit.

ShowForce hold stocks of components for all their range of products and these will be maintained for the duration of their life.

Should a product be discontinued, spare parts stocks will be maintained, but in the event of a part becoming unavailable ShowerForce reserve the right to supply a substitute of equal quality.

The following payment methods can be used to obtain spare parts:

By post, pre-payment of proforma invoice by cheque or postal order.

By telephone quoting credit card (Mastercard, Visa or Visa Delta) details.

REPLACEMENT PARTS:

Tel: 01536 409 222 • Fax: 01536 409 201 • E-Mail:spares@newteam.co.uk

CUSTOMER SERVICE HOTLINE:

Tel: 01536 264 012 • Fax: 01536 409 201 • E-Mail:service@newteam.co.uk

Part No. 404-0111 Issue 06/02





GUARANTEE CARD

Please post immediately enclosing a copy of proof of purchase

FOR SHOWERFORCE USE

AFFIX PRODUCT LABEL HERE

This label identifies your product and provides all the information needed

ShowerForce Victorian-T Mixer Shower

Proof of purchase enclosed

YES NO

NAME: _____

ADDRESS: _____

POSTCODE: _____

DATE OF PURCHASE: _____

PRODUCT PURCHASED FROM: _____

TOWN: _____

ShowerForce/NewTeam's philosophy is to offer outstanding products with quality and integrity, please help us by taking the time to answer the following questions. Thank you.

MARKETING INFORMATION

1. Please state your profession: Plumber Builder Electrician Customer
Other (please specify) _____

2. Please state the reason for purchasing a shower: New Build Replacement
Renovation Other (please specify) _____

3. If the product is a replacement shower, please state the type and make of the shower it is replacing: _____

4. What influenced you to purchase the Victorian-T Mixer Shower? Advertisement
Trade Press Recommendation from Stockist Recommendation from Installer
Other (please specify) _____

5. Please state your main reason for purchasing the Victorian-T Mixer Shower:
ShowerForce Product Knowledge Product Features Product Styling Price
Other (please specify) _____

Please tick here if you do not require any further information or product updates from NewTeam

POST BACK
FOLD AND TAPE AS INSTRUCTED OVERLEAF